

© 1965 BY AMP INCORPORATED. ALL RIGHTS RESERVED. AMP PRODUCTS COVERED BY PATENTS AND/OR PATENTS PENDING. APPROVED PER GOVT CONTRACT NO.

REVISIONS				
ZONE	LTR	DESCRIPTION	DATE	APPROVED
A		REVISED Y-660	8-3-66	M.S. J.F.
B		PRINT DIST WAS "23" LOC WAS "AB"	9-24-72	C.O.
C		380306-2 WAS 380306-3	7-7-75	10-23-73
D		.0001 BRIGHT TIN WAS .0002 TIN	EA 1049	1-22-79
E		REVISED PLATING	EA 1515	8-5-80
F		BRIGHT TIN-LEAD WAS BRIGHT TIN	EA 1819	6-18-81
G		REVISED GOLD PLATING	EA 2139	6-17-82
H		OBS 66280-4	ECN 53379	11-19-86
J		OBS 66266-4	ECN 53940	4-24-87
K		REV PER DF-0207		6-16-88

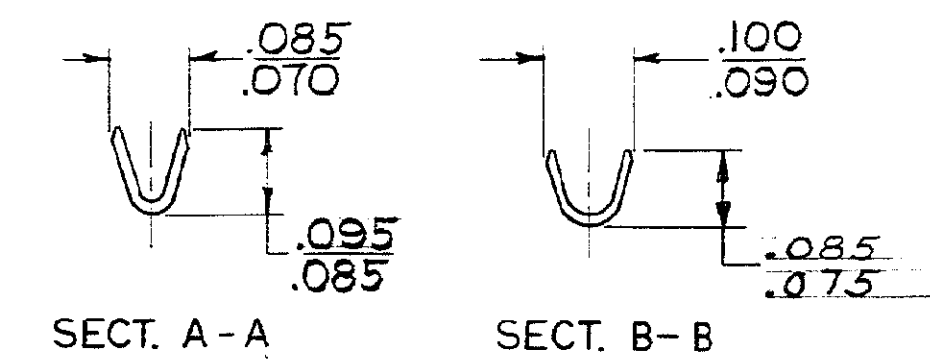

⚠ OBSOLETE PART NO.

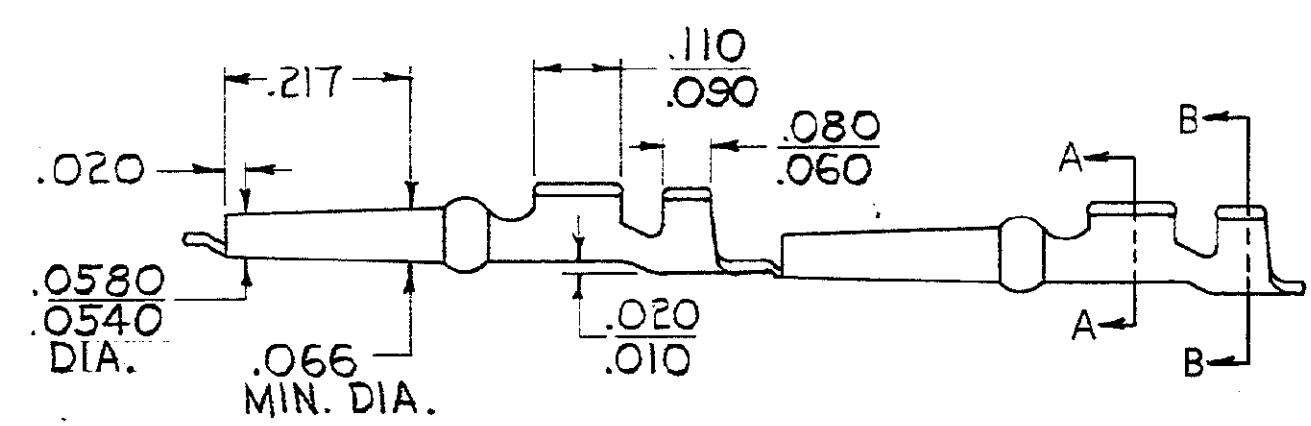
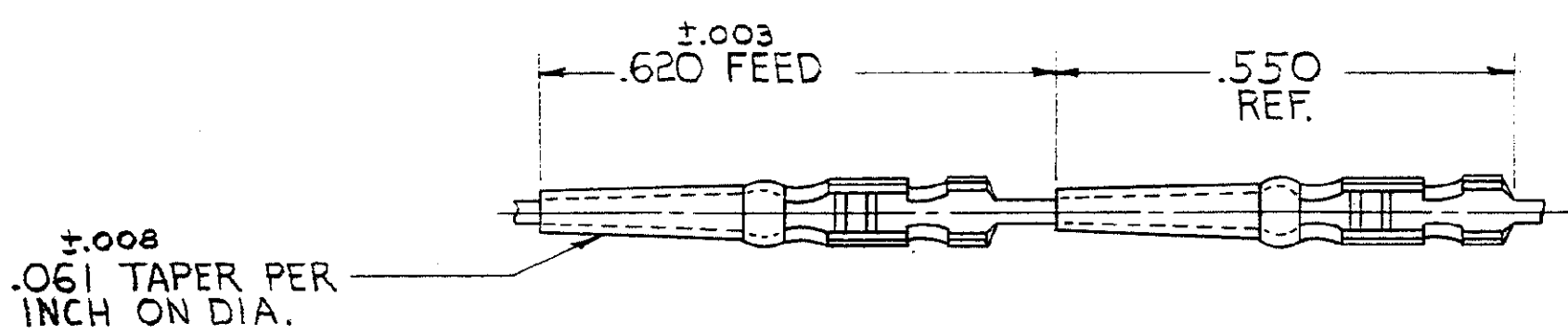
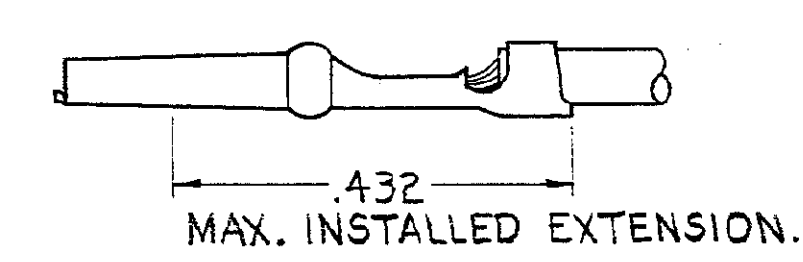
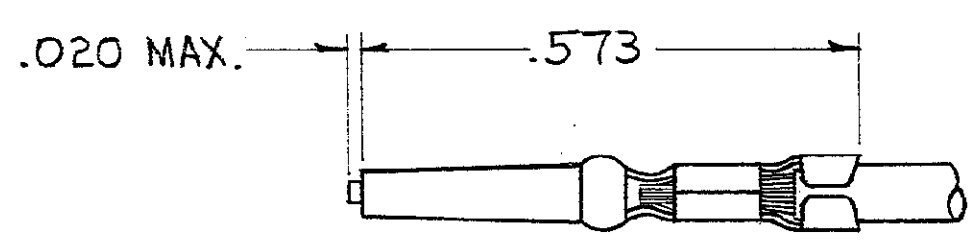
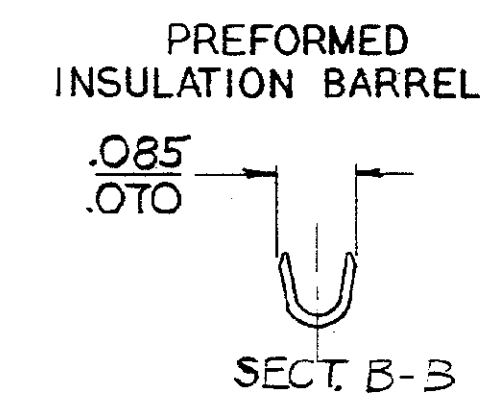
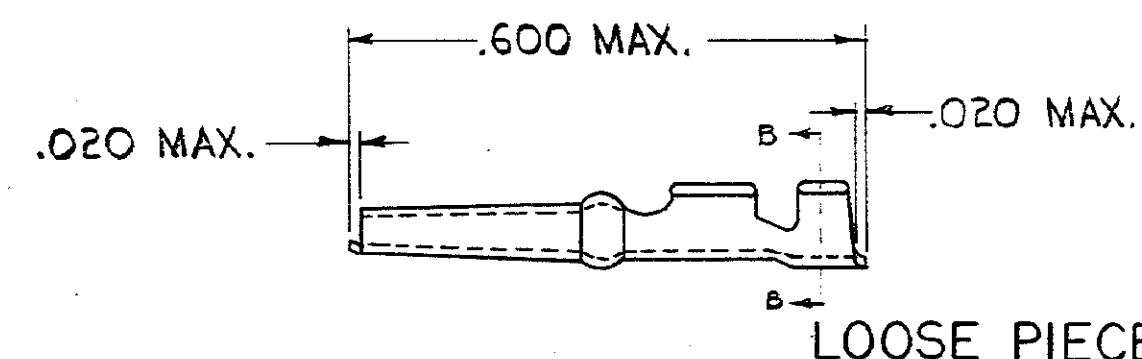

66266-4	66280-4	24-22	.040-.060	PLAIN	380306-2	.042
-3	-3			.00003 GOLD OVER .00005 NICKEL		
-2	-2			.0002 SILVER		
66266-1	66280-1	24-22	.040-.060	.0001 BRIGHT TIN-LEAD	380306-2	.042
STRIP NO.	LP. NO.	WIRE SIZE	INSUL. SIZE	FINISH	INSERT TOOL	HAND TOOL

AMP INFO		QTY REQD	NOMENCLATURE OR DESCRIPTION	PART OR IDENTIFYING NO	LIST OF MATERIALS OR PARTS LIST	
LOC	PRINT DIST					
DF	K/NO					
UNLESS OTHERWISE SPECIFIED DIMENSIONS ARE IN INCHES TOLERANCES ON FRACTIONS DECIMALS ANGLES			CONTRACT NO		AMP INCORPORATED HARRISBURG, PENNSYLVANIA	
= +/0 = 0.10 = ±			DR C. Ortengren DATE 7/20/65		NAME	
MATERIAL .016 COML. BRASS			CHK R. S. Veitch DATE 7/17/65		PIN, TAPER, 53 SERIES	
HEAT TREAT			DSGN ENGR R. Hallert DATE 7/16/65		SIZE CODE IDENT NO NUMBER	
FINISH SEE TABLE			APPR R. Kelleher DATE 7/16/65		C 00779 66266	
			DSGN APPD		SCALE 5-1 WT CALC ACTUAL SHEET 1 OF 1	
			OTHER APPD			

NUMBER 66266