

THIS DRAWING IS UNPUBLISHED. RELEASED FOR PUBLICATION
 (C) COPYRIGHT 19 BY AMP INCORPORATED. ALL RIGHTS RESERVED.

LOC		DIST		REVISIONS			
P	LTR	DESCRIPTION	DATE	DWN	APVD		
CH	11						
		O	INITIAL RELEASE	10/JUL/97	RNP	PRG	
		A	EC 0B20-1629-97	12/NOV/97	RNP	RAR	

- 1 MATERIAL: COPPER ALLOY.
- 2 FINISH: SILVER PLATE 5 μM [200 μIN] THICK MIN. OVER 1.2 μM [50 μIN] THICK MIN. NICKEL OVER 0.1 μM [5 μIN] THICK COPPER FLASH.
- 3. ALL DIMENSIONS ARE REFERENCE.

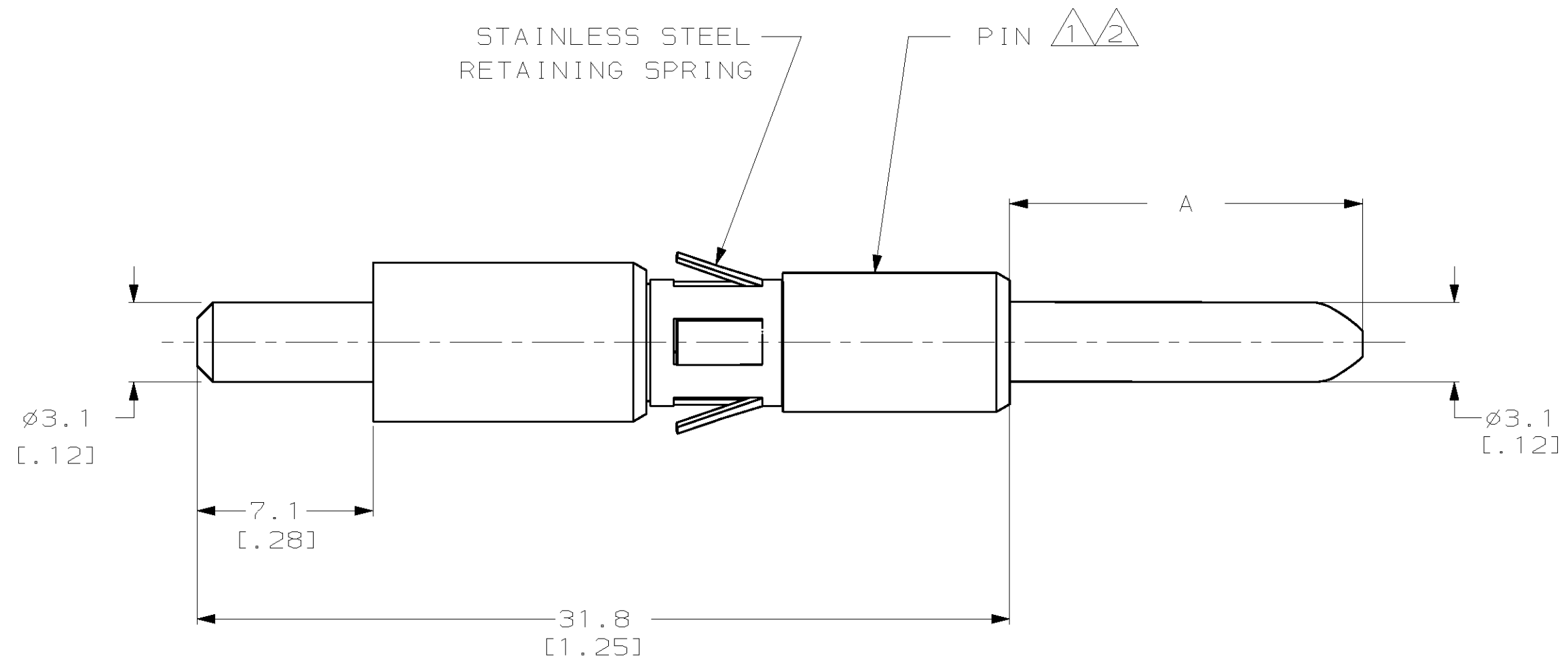
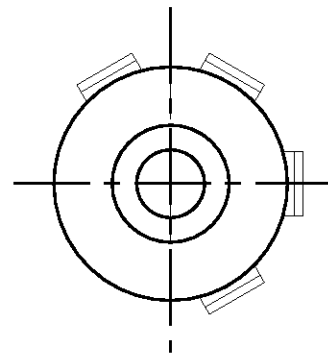

THIRD MATING SEQUENCE	9.7 [.38] A	194251-1 PART NO

<small>THIS DRAWING IS A CONTROLLED DOCUMENT FOR AMP INCORPORATED. IT IS SUBJECT TO CHANGE AND THE CONTROLLING ENGINEERING ORGANIZATION SHOULD BE CONTACTED FOR THE LATEST REVISION.</small>		DWN R N POLK CHK APVD PRODUCT SPEC APPLICATION SPEC WEIGHT CUSTOMER DRAWING	10/JUL/97 - - - - - -	AMP AMP Incorporated Harrisburg, PA 17105-3608 3mm PIN ASSEMBLY HIGH CURRENT, SOLDER TAIL
DIMENSIONS: mm [in]	TOLERANCES UNLESS OTHERWISE SPECIFIED:	MATERIAL	FINISH	SIZE: A2 CAGE CODE: 00779 DRAWING NO: C=194251 SCALE: NONE SHEET: 1 OF 1 REV: A
0 PLC ±- 1 PLC ±- 2 PLC ±- 3 PLC ±- 4 PLC ±- ANGLES ±- FINISH - 2		- 1	- 2	

194251